

AICHI' s SVR realizes the Distribution System' s comprehensive improvement with its incorporated features.

1. Distribution System' s Outlook

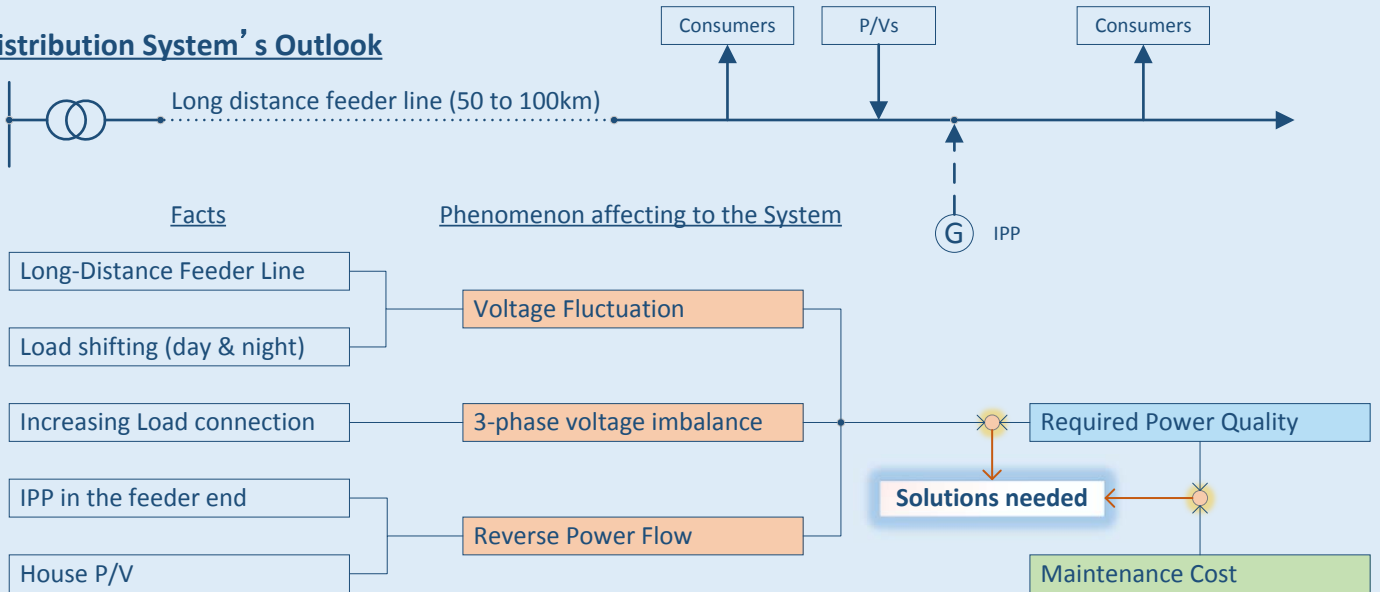

2. Solutions

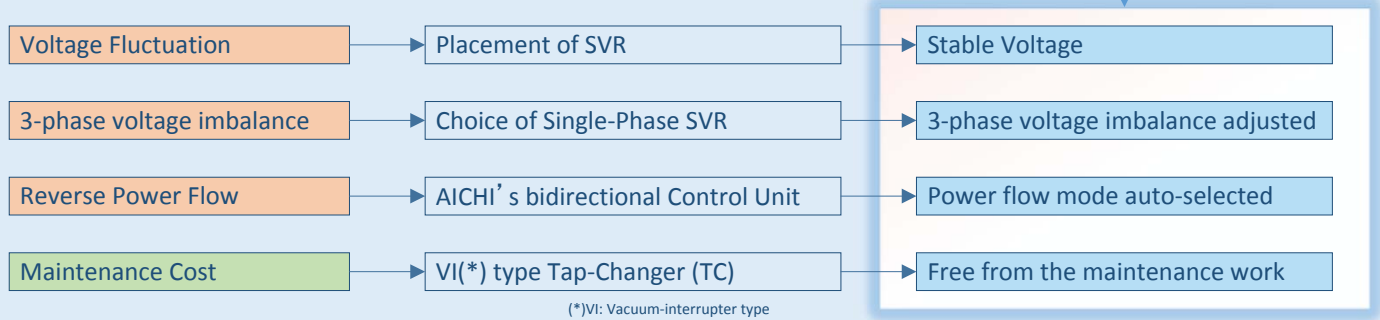

3. Specification

Number of phase	Single(1P), Three(3P)
Voltage (kV)	6.6kV, 11kV, 22kV
Current (A)	440A(6.6kV), 320A(11kV), 200A(22kV)
Numbers of tap	9 taps
Voltage adjustment	-10 to +10% (as of standard)

4. Voltage Compensation Image

